

Suzuki GSX-R600

Advanced Fuel & Ignition system version 2005





Verbindingschema

Suzuki GSX-R600 2005 → AFI05

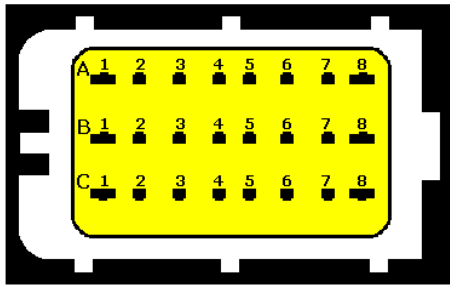

Black

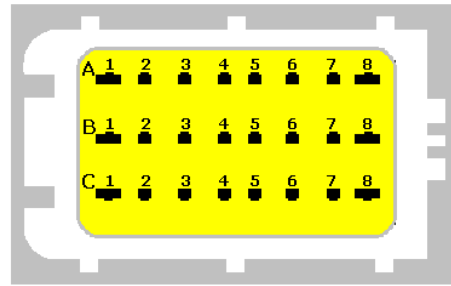

Grey

Con.	Kleur		Omschrijving	Con	Kleur		Omschrijving
A8	Gl		Bobine 3	A8	Zw/W		Massa
A7	Zw		Bobine 2	A7	Zw		Val sensor
A6	W/Bl		Bobine 1	A6	Grijs/Zw		Massa TxRx #1 pin1
A5	Grijs/W		Injector 1	A5	W/Zw		Rx #1 pin2
A4			Douche injector 1	A4	Grijs/Bl		Tx #1 pin3
A3	Grijs/Zw		Injector 2	A3	Zw/Bl		ECT sensor
A2			Douche injector 2	A2	Dgr		IAT sensor
A1	Grijs/Gl		Injector 3	A1	Gr/Zw		MAP sensor
B8	Gr (dik)		Bobine 4	B8	Zw/Br		Massa
B7	Zw/W		Massa	B7	Gr/Bl		referentie krukas sign
B6			-	B6	O/R		Quick-shift ingang
B5			-	B5	Br		Massa nokkenas signaal
B4			-	B4			Tx #2
B3			-	B3	Grijs/Zw		2 ^{de} curve ingang
B2			-	B2	Rose/Zw		TPS sensor
B1	Grijs/R		Injector 4	B1	O/Gl		+12V
C8	Zw/W		Massa	C8	Zw/W		Massa TxRx #2
C7	Zw/W		Massa	C7	R		+5V sensoren
C6			-	C6	Gl/Zw		Toerenteller uitgang
C5			-	C5			Massa
C4	R/Zw		Shift light	C4			Rx #2
C3			Koelvin aansturing	C3	Zw/Gl		Nokkenas signaal
C2			Douche injector 4	C2	Gr/W		Krukas signaal
C1			Douche injector 3	C1	Gl/Zw		Brandstofpomp uitgang

T : +31 (0)492 565220
F : +31 (0)492 565491
W : www.carmo.nl
E : info@carmo.nl

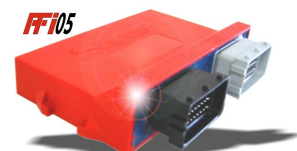



Aanvullende informatie

Voeding AFI05

Voeding van AFI05 unit (oranje/geel: B1) verbinden met oranje, nabij zekeringkast. Deze wordt d.m.v. run/off switch verbonden met rood (+12V continu).

Voeding AIM

Voor voeding AIM/MXL systeem kan oranje/groen(+) en zwart/wit(-) worden gebruikt uit de multipole connector waarop het origineel dashboard is aangesloten.

Run/off – start schakelaar







Originele kleur kabelboom		Kleur schakelaar		Omschrijving
Rood		Geel/Rood		+12V continu
Oranje/Rood		Geel		
Oranje		Zwart/Geel		
Oranje/Zwart		Wit/Zwart		
Oranje/Wit		Wit		
Geel/Groen		Zwart/Rood		Startknop
Oranje		Rood		

Gear position

Blauw/Zwart in connector bij dashboard (neutraallamp origineel dash) kan worden gebruikt voor berekening van stand versnellingsbak (Gearposition).

Lambda/AirFuel-sensor

Voor voeding Lambda/AF-sensor wordt oranje/rood (FAN) gebruikt. Deze voeding is gezekeerd en wordt geschakeld via run/off switch.

Originele kleur kabelboom		AMP	Interface Lambda		Omschrijving
Oranje/Rood		2/2	Rood		Voeding +12V
Zwart		1/2	Zwart		Massa
Naar AIM(MXL)					
Wit		1/2	Wit		Signaal 0..5V
Zwart		2/2	Zwart		Massa

T : +31 (0)492 565220
F : +31 (0)492 565491
W : www.carmo.nl
E : info@carmo.nl

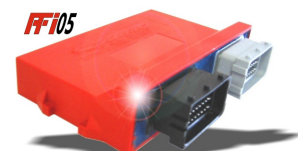



Aansluitschema voor opties AFI05

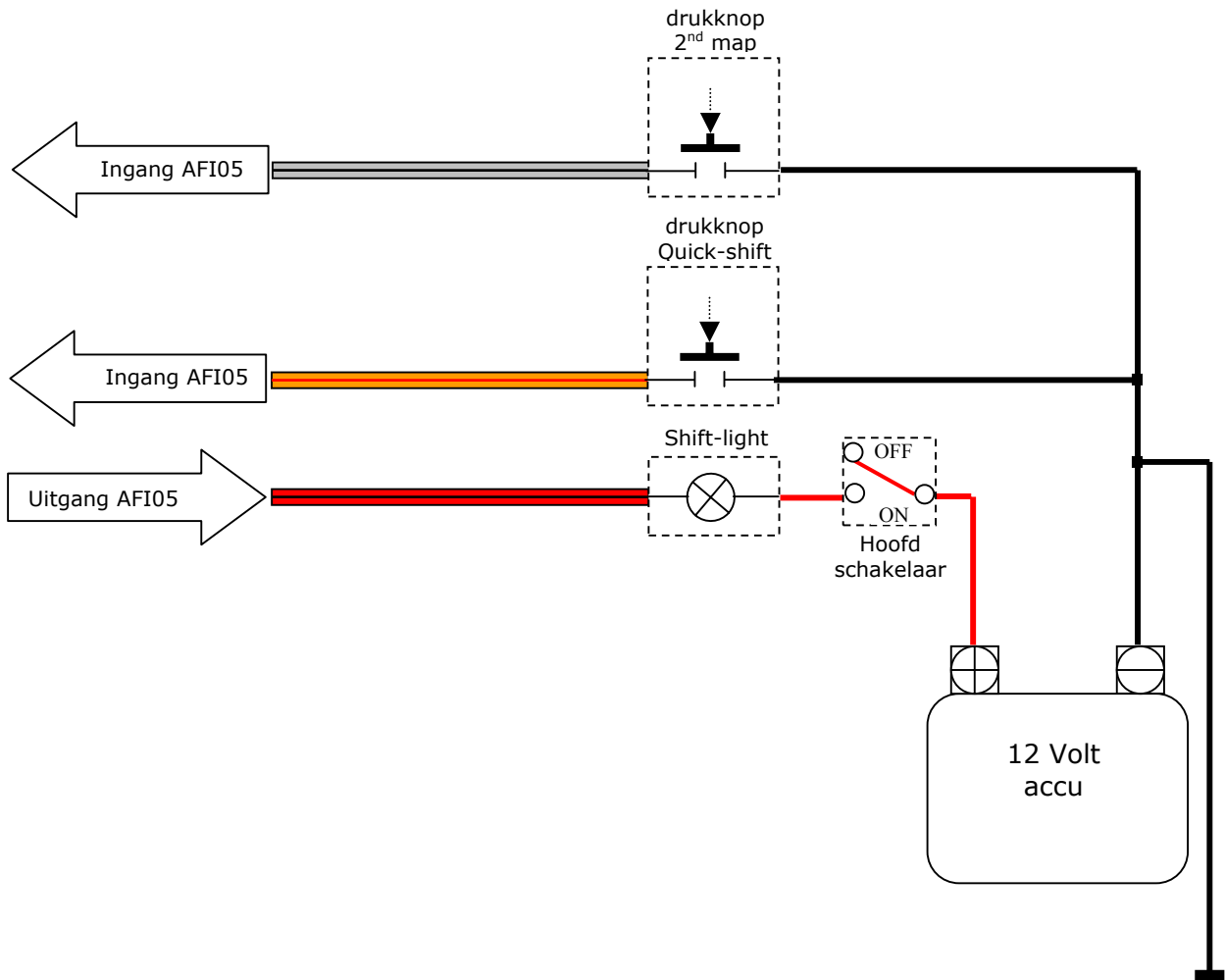

T : +31 (0)492 565220
F : +31 (0)492 565491
W : www.carmo.nl
E : info@carmo.nl

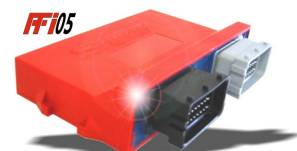



Connection diagram
Suzuki GSX-R600 2005 → AFI05

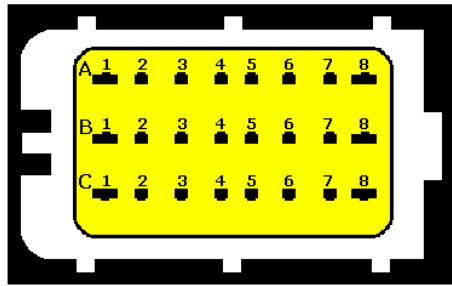

Black

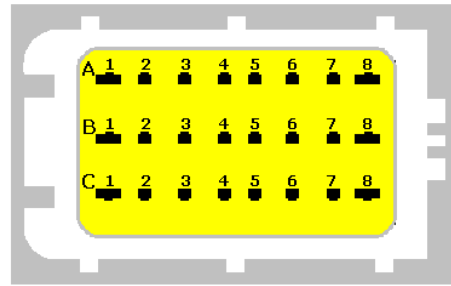

Grey

Con.	Color		Description	Con	Color		Description
A8	Y		Ignitioncoil #3	A8	Bk/W		Ground
A7	Bk		Ignitioncoil #2	A7	Bk		Down sensor
A6	W/Bl		Ignitioncoil #1	A6	Gry/Bk		Ground TxRx #1 pin1
A5	Gry/W		Injector #1	A5	W/Bk		Rx #1 pin 2
A4			Shower injector #1	A4	Gry/Bl		Tx #1 pin 3
A3	Gry/Bk		Injector #2	A3	Bk/Bl		ECT sensor
A2			Shower injector #2	A2	Dgr		IAT sensor
A1	Gry/Y		Injector #3	A1	Gr/Bk		MAP sensor
B8	Gr (big)		Ignitioncoil #4	B8	Bk/Br		Ground
B7	Bk/W		Ground	B7	Gr/Bl		reference crank-signal
B6			-	B6	O/R		Quick-shift ingang
B5			-	B5	Br		Ground Cam-signal
B4			-	B4			Tx #2
B3			-	B3	Gry/Bk		2 ^{de} Map input
B2			-	B2	P/Bk		TPS sensor
B1	Gry/R		Injector #4	B1	O/Y		+12V
C8	Bk/W		Ground	C8	Bk/W		Ground TxRx #2
C7	Bk/W		Ground	C7	R		+5V sensor powersupply
C6			-	C6	Y/Bl		Tacho output
C5			-	C5			Ground
C4	R/Bk		Shift light	C4			Rx #2
C3			Fan output	C3	Bk/Y		Cam-signal
C2			Shower injector #4	C2	Gr/W		Crank-signal
C1			Shower injector #3	C1	Y/Bk		Fuelpump relay output

T : +31 (0)492 565220
F : +31 (0)492 565491
W : www.carmo.nl
E : info@carmo.nl

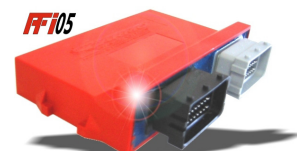



Additional information















Powersupply AFI05

Connect power AFI05 (orange/yellow: B1) with orange, near fuse-box. Orange is switched to red (+12V continue) with the run/off switch.

Powersupply AIM

Use orange/green(+) and black/white(-) from the multipole connector at the front end of the bike. This connector is used for the dashboard originally.

Run/off – start switch

Original color wiringloom		Color switch		Description
Red		Yellow/Red		+12V continu
Orange/Red		Yellow		
Orange		Black/Yellow		
Orange/Black		White/Black		
Orange/White		White		
Yellow/Green		Black/Red		Startswitch
Orange		Red		

Gear position

Blue/Black in connector near dashboard (neutral indicator original dash) is used to calculate gearposition for AIM (MXL)

Lambda/AirFuel-sensor

Use orange/red (FAN) to power the lambda/AF-sensor. This powerlead uses the FAN-fuse in the fusebox and is switched using the run-off switch.

Original color wiringloom	AMP	Interface Lambda	Description
Orange/Red	2/2	Red	+12V Power
Black	1/2	Black	Ground
Naar AIM(MXL)			
White	1/2	White	Signal 0..5V
Black	2/2	Black	Ground

T : +31 (0)492 565220
F : +31 (0)492 565491
W : www.carmo.nl
E : info@carmo.nl

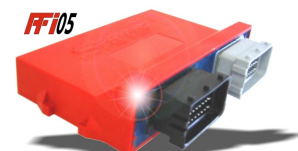



Connection diagram Options AFI05

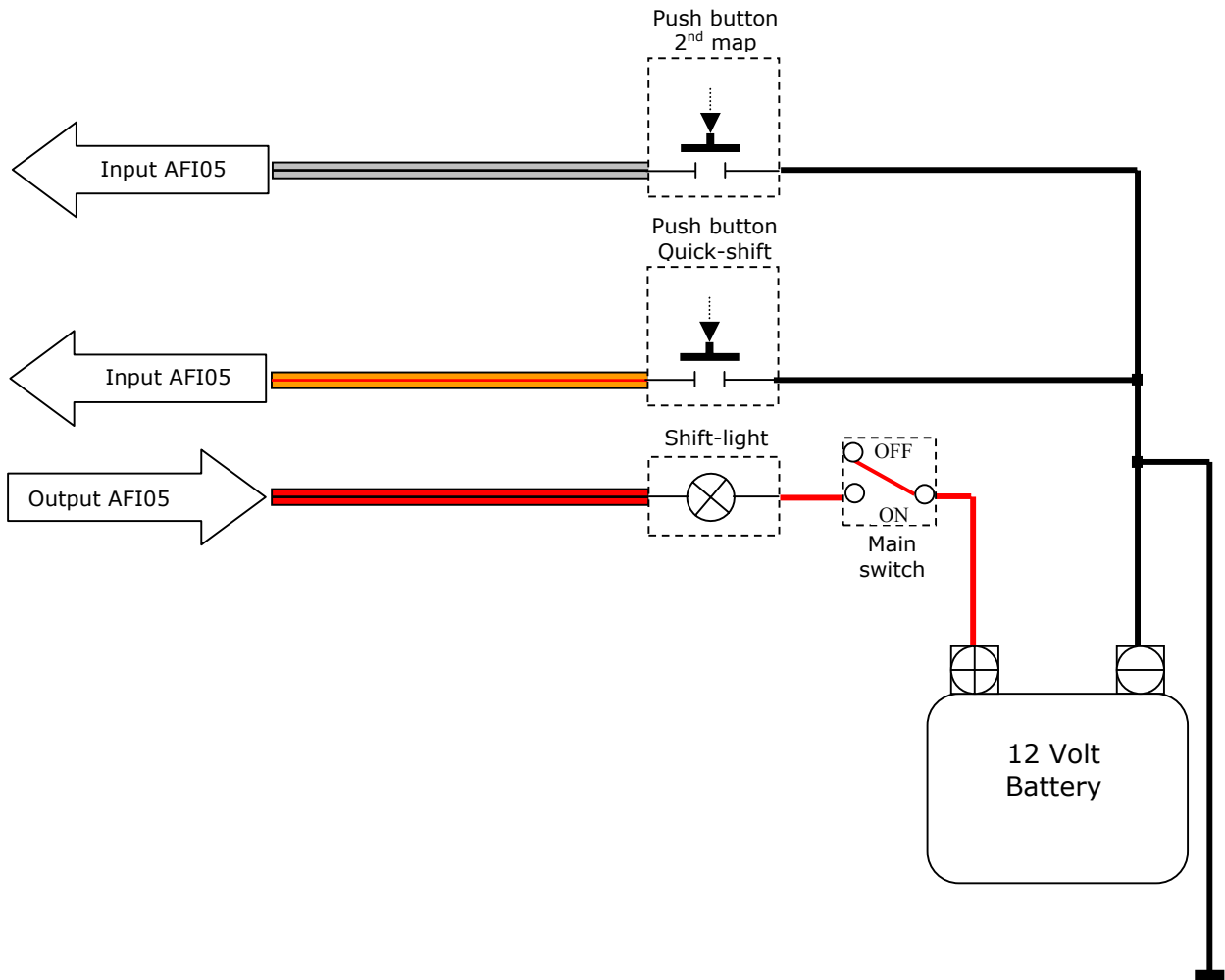

T : +31 (0)492 565220
F : +31 (0)492 565491
W : www.carmo.nl
E : info@carmo.nl

